

Hot rolled Steel Plates, Sheets and Coils

Steels resistant to wear and surface pressure

Raex®

Raex is a hardened steel grade with excellent hardness and strength properties and is resistant to abrasion and extreme surface pressure. Raex as a material extends the lifespan of machinery, decreases the impacts of wear in structural components and saves costs. Thanks to its high-strength properties, Raex can be used for light-weight products with elegant shape and high energy efficiency. Raex allows innovative and environmentally sound product development. Raex is easy to weld, cut and has reasonably good formability. Safe work methods must be followed in workshop processing.

Applications

- Buckets and cutting edges of earth moving machines
- Wearing parts of mining machines
- Wearing parts of concrete mixing plants and wood processing machines
- Platform structures
- Feeders, funnels

Ruukki is a metal expert you can rely on all the way, whenever you need metal based materials, components, systems or total solutions. We constantly develop our product range and operating models to match your needs.

- **Description of the steel grades**

Raex 300, Raex 400, Raex 450 and Raex 500 are hardened abrasion resistant steel grades. The number of the designation indicates the average Brinell hardness value: 300, 400, 450 and 500 HBW.

- **Product forms**

Cut lengths and heavy plates.
In addition, plates are delivered shop-primed, cut shapes, bent and with edge bevels.

- **Delivery condition**

Hardened.

- **Dimensions**

Thickness ranges for cut lengths and heavy plates are presented in Table 1.

- **Tolerances on dimensions and shapes**

- **Plate products**

Thickness EN 10029 Class A. Width and length EN 10029.

Flatness EN 10029, Class N normal tolerances on flatness, steel type H.

- **Cut lengths**

Thickness, width and length EN 10051.

Flatness EN 10029 Class N, steel type H.

- **Chemical composition and microstructure**

The chemical composition of boron steels (cast analysis) is stated in Table 2. The typical microstructure of hardened steels is martensitic.

- **Carbon equivalent value (CEV)**

Typical carbon equivalent values for each steel grade and product form are shown in table 3.

- **Hardness**

The typical hardness values of steel grades for different product forms and plate thicknesses are presented in Table 4.

- **Abrasion resistance**

The microstructure of abrasion resistant steel is martensitic, which guarantees high hardness and tensile strength. The hardness of Raex 500 is over three times that of S355 structural steel, Raex 450 is nearly three times and Raex 400 is two and a half times as hard as S355 structural steels. High hardness and tensile strength give steel high resistance to abrasion in abrasive environments. Good abrasion resistance is the most important basis for choosing these steels.

- **Mechanical properties**

Typical mechanical properties are presented in Table 5.

- **Materials testing**

Hardness is measured in Brinell units (HBW) in compliance with the EN ISO 6506-1 standard from a depth of 0.3 – 2 mm from the steel surface. The measurement depth is determined on the basis of product form and plate thickness.

- **Surface finish**

EN 10163-2 Class A3. Repair welding of plates is not permitted in plate production of Raex steels.

- **Dead Flat process (straightening rolling) of cut lengths**

Raex cut lengths delivered from the works are delivered as Dead Flat (DF) or straightening rolled. The DF treatment means that cut lengths are cold formed throughout their thickness. This releases any residual stresses and gives excellent flatness properties. The control of welding distortions becomes easier and reproducibility in flanging is improved. When being cut, DF products will maintain their flatness and no further straightening is required before the subsequent process stages. Flat and stress-relieved cut lengths will reduce the throughput time in sheet metal processing. The DF process will be noted in the inspection document.

- **Inspection document**

On the customer's request, either a Test report 2.2 or Inspection certificate 3.1 in compliance with standard EN 10204 is granted to Raex steels. The inspection document states the chemical composition of steel based on cast analysis and hardness in delivery condition.

- **Cold forming**

Raex 320/400/450 steels can be cold formed up to the thickness of 20 mm. Forming temperature must be a minimum of +20 °C and a maximum of +200 °C. Standard values for free bending and flanging are presented in Table 6. Due to high hardness of the Raex steels, the bending force needed, springback and bending radius are higher than those of traditional structural steels. It is recommended to contact Ruukki's Technical Customer Service prior to cold-forming of over 20 mm thick plates or Raex 500 steel. Preheating is always required in the bending of over 20 mm thick plates. The recommended forming temperature is 150 – 200 °C. Preheating improves the deformation properties of the plate and guarantees successful bending.

High-quality technology and tools that are in good condition should be used for forming. Wear and tear of tools, insufficient lubrication, surface defects on plates and burrs in cut edges will impair forming quality. It is recommended to use the widest possible bending radius. The plate is bent in a single pass to the ultimate curvature to avoid springback during the work. Lubrication of bending surfaces reduces friction. A basic requirement for successful flanging and bending is that, prior to commencing work, a plate that has been stored in a cold atmosphere is allowed to warm up thoroughly to room temperature +20 °C. Particular care must be taken when forming all hardened plates and sheets.

- **Welding**

The weldability of Raex steels is good and they can be welded using all common welding procedures. Raex steels can also be joined with other steels by welding. Special instructions for high-strength steels must be followed. The choice of working temperature, consumables and welding energy must be made in compliance with the instructions. The surfaces of the weld groove must be dry and clean. In addition, the manufacturer's recommendations must be adhered to in detail regarding the storage, use and possible re-drying of the consumables. Welding should be finished off by grinding all edges and corners smooth in order to enhance the fatigue durability of the structure. Raex steel is not suited for post-weld heat treatments, because they have a tendency to weaken the strength, hardness and abrasion resistance of hardened steel.

- **Working temperature**

The need to have an elevated working temperature is determined mainly on the basis of plate thickness and the carbon equivalent value of the steel grade in question. The typical carbon equivalent values for each steel grade and product are presented in Table 3. The plate-specific carbon equivalent value can be verified from the inspection document in order to accurately define working temperature. Increasing the working temperature slows the cooling of welded joints, which decreases the generation of a hard and brittle microstructure in the heat affected zone (HAZ). It is recommended to increase the working temperature of Raex 400 steels, when the combined plate thickness exceeds about 40 mm. The respective thickness is about 30 mm for Raex 450 steel and about 20 mm for Raex 500 steel. Raex 320 steel does not usually require an elevated working temperature in a normal workshop environment, thanks to its small plate thickness.

The recommended welding temperatures for Raex steels are presented in Table 7. Higher temperatures

than those indicated in the Table must be used when welding robust and complicated structures or when welding in a particularly demanding environment. However, the working temperature must not exceed +200 °C. Preheating is particularly important in tack welding because a small and local weld cools down quickly.

- **Welding consumables**

The ferritic welding consumables used on the welding of hardened steels must be low-hydrogen. There are a number of advantages in using under-matching filler metals compared to using matching filler metals: stress in the weld remains at a lower level and the sensitivity to cold-cracking caused by hydrogen is smaller. In addition, the need to have a higher working temperature is also decreased. Undermatching filler metals have better impact strength and formability than harder weld metals.

Undermatching filler metals are used if the welded joints in the structures are not exposed to heavy loading. Correspondingly, the use of matching filler metals is necessary, if a welded joint is exposed to hard wear or the filler metal is required to have high strength. When matching strength properties are required, it is usually sufficient to weld 2 – 3 layers of capping runs with matching filler metals when welding thick plates. The fill up runs can be made using undermatching filler metal and thus take advantage of the benefits it offers. Hydrogen content $HD \leq 5 \text{ ml/100 g}$. Ferritic welding consumables are either so-called non-alloyed or alloyed filler metals. The strength of weld produced by non-alloyed filler metals remains lower than the strength of the hardened base material. In this case we talk about "undermatching" filler metals, such as the standardised welding consumables E 7018, AWS A5.17, AWS A5.18 and AWS A5.20. Correspondingly, alloyed filler metals which produce high-strength weld are referred to as "matching" filler metals, such as the standardised welding consumables E 11018, E 9018, AWS A5.28, AWS A5.29. Ferritic welding consumables recommended for Raex steels are presented in Table 8.

Alternatively, welding consumables intended for the welding of stainless austenitic steels can also be used for hardened steels in joints where undermatching welding consumable is required. The weld metal produced by austenitic welding consumables has excellent tensile strength and forming properties. The weld metal will be significantly softer than that produced by using ferritic welding consumables. In addition, the stress level in the joint remains lower. Austenitic welding consumables are not susceptible to cold-cracking attributable to hydrogen and their hydrogen content is not always even indicated. It is usually not necessary to increase the working tem-

perature when welding with austenitic welding consumables. The advantages of austenitic stainless steel welding consumables are usually best exploited in work site conditions and repair welding.

- **Arc energy**

Achieving optimal properties in welded structures requires the selection of arc energy in such a way that the cooling time $t_{8/5}$ for a welded joint is a minimum of 10 s and a maximum of 20 s. In practical welding work, the cooling time of 10 s is equivalent to the allowable arc energy minimum value and cooling time of 20 s corresponds to the allowable arc energy maximum value. For instance, for MAG welding of a 10 mm thick plate, this cooling time requirement corresponds to the arc energy range of 1.2 – 1.7 kJ/mm. The value $t_{8/5}$ means the cooling time for a joint over the temperature range of 800 – 500°C, which is crucial from the point of view of the HAZ microstructure.

Too rapid cooling increases the hardening of HAZ and makes the material more susceptible to cold-cracking. In order to ensure the integrity of the joint, the arc energy minimum value must be known, because it guarantees a sufficiently long cooling time. Too slow cooling decreases the hardness, strength and impact strength of the joint. These factors are used for determining the allowable maximum value for arc energy. Slow cooling and/or high arc energy create a narrow band that is softer than the base material in HAZ. This is typical for all hardened steels.

- **Flame cutting**

Flame cutting is the most commonly used thermal cutting method for, especially, thicker steel plates. Special care must be taken in the flame cutting of hardened steels; particularly so when cutting thick plates. A tempered martensitic microstructure layer forms under the flame cut surface of hardened steels due to residual cutting heat. The layer is softer than the other hardened structure, which remains in the hardened condition during flame cutting.

Thick plates must be preheated before flame cutting, the recommended temperatures are presented in Table 9. In practice, it preheating is recommended whenever the thickness of the plate exceeds 10 mm when cutting steel grades Raex 400/450/500. Raex 320 in ordinary workshop conditions does not require preheating.

The maximum allowable plate temperature (working temperature) must be kept below 200°C to ensure that the abrasion resistance properties remain in compliance with requirements throughout the plate. The cooling of

a cut surface must not be accelerated. A basic requirement for successful flame cutting is that, prior to commencing the work, a plate that has been stored in a cold atmosphere is allowed to warm up thoroughly to room temperature (+20°C).

- **Heat treatment**

Hardened steels are not intended to be heat treated. Tempering in the maximum temperature of 200°C, is the only heat treatment which will maintain the abrasion resistance properties of the plate at a good level. Heat treatment in higher temperatures decreases the strength, hardness and abrasion resistance properties of steels.

- **Mechanical cutting**

Hardened steels can be cut mechanically. This is, however, challenging because the plate is almost as hard as the cutting blade. High shear force is needed due to the high tensile strength of the steel. High surface pressures during cutting are directed at the blade, which increases wear. The most recommended cutting tool is a straight cutting tool. The most important cutting parameters are blade clearance and blade angle. The hardness of the blade is of great importance. Raex 320/400/450 steels can be cut with heavy-duty cutting machines, but the hardness of the cutting blade must exceed 53 HRC. The mechanical cutting of Raex 500 steel can be recommended only with certain reservations, and then only at thicknesses of less than 10 mm and blade hardness over 57 HRC. Concepts of mechanical cutting are presented in Figure 1. Examples of mechanical cutting specifications of Raex 100 steels are given in Table 10.

It is recommended to benefit from the know-how on mechanical cutting accumulated in each workshop when cutting hard and high-strength steel plates. A cutter-specific cutting data chart is helpful for determining the correct parameters.

- **Machining**

Robust machinery and hard metal bits are recommended for machining. Holes can be drilled even using high-speed steel bits if the tool geometry and cutting fluid are correctly chosen.

- **Occupational safety**

Special care must be taken in all stages of handling of hardened steels. Flanging is challenging due to the high strength and high flexural stresses of the plate. If the bending radius, for example, is too small and a crack is created in the bending point, the plate may fly from the bending tool in the direction of the bend. Those bending the plate must take appropriate precautions to protect

themselves and no outsiders must be allowed in the area. The safest location is usually by the bending machine. The handling instructions of the steel supplier and safety instructions of the workshop must be adhered to in detail. New employees must receive appropriate training before they are allowed to process hardened steels.

● **Further information**

Further information can be found in the following data sheets: Boron Steel, Welding, Welding consumables, Thermal cutting and flame straightening, Flanging and forming, Mechanical cutting and Machining.

● **Thickness ranges**

Table 1

	Cut lengths mm	Heavy plate mm
Raex 300	2.5 – 8.0	–
Raex 400	2.5 – 6.4	5 – 60
Raex 450	3.0 – 6.4	6 – 60
Raex 500	4.0 – 5.0	5 – 60

● **Chemical composition**

Table 2

	Content %, maximum (cast analysis)								
	C	Si	Mn	P	S	Cr	Ni	Mo	B
Raex 300	0.18	0.70	1.70	0.025	0.015	1.50	0.40	0.50	0.005
Raex 400	0.25	0.70	1.70	0.025	0.015	1.50	0.70	0.50	0.005
Raex 450	0.26	0.70	1.70	0.025	0.015	1.00	0.70	0.50	0.005
Raex 500	0.30	0.70	1.70	0.025	0.015	1.00	0.80	0.50	0.005

In addition, aluminium (Al) and/or titanium (Ti) can be used as micro-alloy material.

● **Carbon equivalent CEV. Typical values**

Table 3

	Thickness mm	CEV	Product
Raex 300	2 – 8	0.47	Cut lengths
Raex 400	2.5 – 6.4	0.49	Cut lengths
Raex 400	5 – 12	0.45	Heavy plates
Raex 400	(12) – 30	0.50	Heavy plates
Raex 400	(30) – 60	0.56	Heavy plates
Raex 450	3.0 – 6.4	0.53	Cut lengths
Raex 450	6 – 30	0.50	Heavy plates
Raex 450	(30) – 60	0.58	Heavy plates
Raex 500	4.0 – 5.5	0.55	Cut lengths
Raex 500	5 – 60	0.64	Heavy plates

$$CEV = C + Mn / 6 + (Cr + Mo + V) / 5 + (Ni + Cu) / 15$$

• **Hardness for each product and thickness**

Table 4

	Product	Thickness mm	Hardness range HBW
Raex 300	Cut lengths	2.0 – 8.0	270 – 390
Raex 400	Cut lengths	2.5 – 6.4	360 – 420
Raex 400	Heavy plates	5 – 15	360 – 420
Raex 400	Heavy plates	(15) – 30	360 – 450
Raex 400	Heavy plates	(30) – 60	360 – 480
Raex 450	Cut lengths	3.0 – 6.4	420 – 500
Raex 450	Heavy plates	6 – 60	420 – 500
Raex 500	Cut lengths	4.0 – 5.5	450 – 540
Raex 500	Heavy plates	5 – 60	450 – 540

• **Typical mechanical properties**

Table 5

Steel grade	Yield strength R _{p0.2} MPa	Tensile strength R _m MPa	Elongation A ₅ %	Impact strength, Charpy V 20 J
Raex 300	900	1000	11	-40 C
Raex 400	1000	1250	10	-40 C
Raex 450	1200	1450	8	-40 C
Raex 500	1250	1600	8	-30 C

The values for steel grades Raex 400, Raex 450 and Raex 500 are typical mechanical properties tested for the plate thickness of 20 mm.

The values for steel grade Raex 300 are typical mechanical properties tested for the plate thickness of 8 mm.

• **Free bending. Directive values**

Table 6

	Thickness mm	Free bending < 90° Plunger radius or curvature / plate thickness R/t Bend line position vs. rolling direction		Gap width / plate thickness W/t		Bending to 90° W/t V channel
		Transversal	Longitudinal	Transversal	Longitudinal	
Raex 300	2 – 8	3	3	9	9	≈ 15
Raex 400	2,5 – 6	3	3	9	9	≈ 15
Raex 400	(6) – 20	3	4	9	11	≈ 15
Raex 450	3 – 20	4	5	11	13	≈ 15
Raex 500	5 – 20	≈ 10	≈ 12	23	27	–

It is recommended to consult Ruukki Technical Customer Service when bending Raex 500 steel or plates thicker than 20 mm.

• Recommended working temperatures in welding °C

Table 7

Welding method Hydrogen content of the weld HD	Minimum arc energy E kJ/ mm	Combined plate thickness t, mm											
		10	20	30	40	50	60	70	80	90	100	110	120
Raex 400	MAG solid wire, flux cored welding, electrode HD ≤ 5 ml / 100g	1.5	20		50	75	125	150					
		2	20				125			150			
		2.5	20				100			125			
	Flux cored welding, electrode HD = 5 - 10 ml / 100 g	1.5	20	100	125		175			200			
		2	20		100	125	150		175				
		2.5	20			75	125	150		175			
	Submerged arc welding HD = 5 - 10 ml / 100 g	1.5	20	50	100	125	150	175					
		2	20			75	125	150		175			
		2.5	20				100	125		150			
Raex 500	MAG solid wire, flux cored welding, electrode HD ≤ 5 ml / 100g	1.5	20	75	125	150		175					
		2	20		75	125		150			175		
		2.5	20			75	125		150			175	
	Flux cored welding, electrode HD = 5 - 10 ml / 100 g	1.5	20	150	175	200 ¹⁾							
		2	20	100	150	175	200 ¹⁾						
		2.5	20	50	100	150	200 ¹⁾						
	Submerged arc welding HD = 5 - 10 ml / 100 g	1.5	20	100	150	175	200 ¹⁾						
		2	20	50	100	150	200 ¹⁾						
		2.5	20		50	100	200 ¹⁾						

No elevated working temperature is required in the welding of Raex 300 steel.
Working temperatures over 200° may impair mechanical properties.

$$E = \frac{60 \cdot U \cdot I}{100 \cdot v}$$

E = arc energy (kJ/mm) I = welding current (A)
U = arc voltage (V) v = welding speed (mm/min)

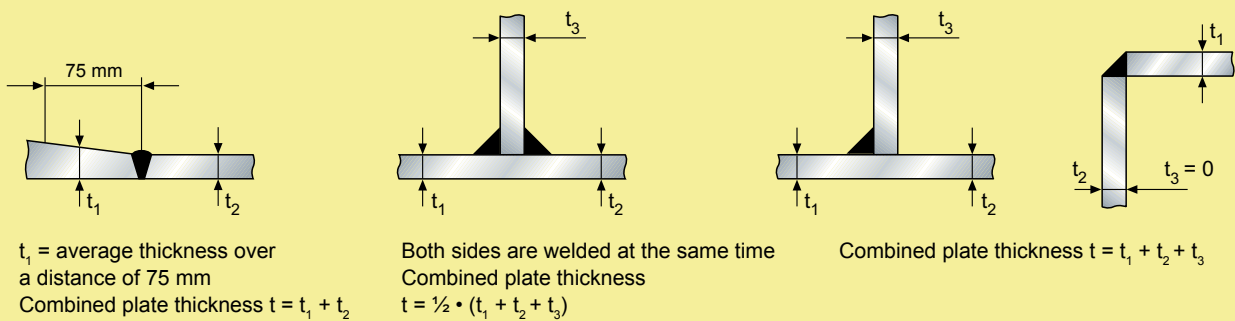

• Recommended welding consumables for the welding of Raex® abrasion resistant steels

Table 8

Welding method	Manufacturer / representative	Welding consumable	
		Low alloy, 'undermatching' filler material (the yield strength of the filler material is lower than that of the parent material)	High alloy, 'matching' filler material (the filler and the parent materials' yield strengths are equal)
Manual metal arc welding Universal electrode	ELGA	P62 MR	P110
	ESAB	OK 48.00	OK 78.16
	FILARC	Filarc 35	Filarc 118
	IMPOMET OY	Oerlikon Supercito	Oerlikon Cromocord Kb
	LINCOLN ELECTRIC	CONARC 48	CONARC 85
	RETCO OY	COMET J 50+	MOLYCROM 15
	OY UDDEHOLM AB	Fox EV 50	SH Schwartz 3 K Ni
Manual metal arc welding High efficiency electrode	ELGA	MAXETA 24	MAXETA 110
	ESAB	OK 38.65	OK 38.65
	FILARC	Filarc C6HH	
	IMPOMET OY	Oerlikon Febacito 160S	Oerlikon Febacito 160S
	LINCOLN ELECTRIC	CONARC V 180	
RETCO OY	COMET J 160		
MAG welding Solid wire	ELGA	Elgamatic 100	Elgamatic 135
	ESAB	OK Autrod 12.51	OK Autrod 13.12
	IMPOMET OY	Oerlikon Carbofil 1	Oerlikon Carbofil CrMo 1
	LINCOLN ELECTRIC	LNM 26	LNM MONIVA
	RETCO OY	IS-10 BRONZE	
	OY UDDEHOLM AB	EMK6	Union NiMoCr
Filler wire welding Metal-cored wire	ESAB	OK Tubrod 14.12	OK Tubrod 14.03
	FILARC	Filarc PZ 6102	Filarc PZ 6102
	IMPOMET OY	Oerlikon Fluxofil M8	Oerlikon Fluxofil 36
	LINCOLN ELECTRIC	OS MC 710-H	OS MC 1100
	RETCO OY	Trimark METALLOY-76	
OY UDDEHOLM AB	MV 70		
Filler wire welding Flux-cored wire	ELGA	DWA 50	110B
	ESAB	OK Tubrod 15.14	OK Tubrod 15.09
	FILARC	Filarc PZ 6113	Filarc PZ 6148
	IMPOMET OY	Oerlikon Fluxofil 14HD	Oerlikon Fluxofil 14HD
	LINCOLN ELECTRIC	OS 71 E-H	
	RETCO OY	Trimark TM-770	
OY UDDEHOLM AB	RV 71		
Submerged arc welding	ELGA	Elfasaw 102 / Elgaflex 251 B	
	ESAB	OK Autrod 12.22 / OK Flux 10.71	OK Autrod 13.43 / OK Flux 10.62
	IMPOMET OY	Oerlikon OE-S2 / Oerlikon OP 122	Oerlikon OE-S3NiMo1/ Oerlikon OP 121TT
	LINCOLN ELECTRIC	L-61 / FX P 230	LNS168 / FX P230

• **Recommended working temperatures for thermal cutting °C**

Table 9

	Thickness mm	Working temperature °C
Raex 400	15 – 30	50 – 75
	(30) – 60	75 – 125
Raex 450	15 – 60	75 – 125
Raex 500	10 – 60	125 – 175

No elevated working temperature is needed for Raex 300 (2 – 8 mm) steel.

• **Cutting geometry and terms**

Sections of the cut surface

Figure 1

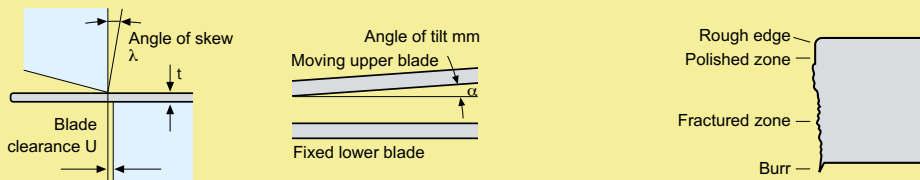

• **Mechanical cutting of Raex® 400 steels**

Table 10

	Tensile strength		Elongation Plate thickness mm t	Mechanical cutting, guideline values			Shearing force a x 10 ³ N
	R _m N/mm ²	A ₅ %		Blade clearance mm U	Angle of tilt α °	Angle of skew λ °	
Raex 400	1250	10	6	0.60 – 0.72	3 – 4	0 – 3	150 – 200
			8	0.80 – 1.28	3 – 5	0 – 5	250 – 350
			10	1.00 – 1.80	4 – 6	0 – 5	300 – 450
			12	1.20 – 2.16	4 – 6	0 – 5	400 – 600

• **Our Customer Service is happy to give you further information**

Sales, Technical Customer Support

info.metals@ruukki.com

Rautaruukki Corporation, P.O. Box 138, FI-00811 Helsinki, Finland.

tel. +358 20 5911

www.ruukki.com

This data sheet is accurate to the best of our knowledge and understanding. Although every effort has been made to ensure accuracy, the company cannot accept any responsibility for any direct or indirect damages resulting from possible errors or incorrect application of the information of this publication. We reserve the right to make changes.